

# GCSE Physics

# Required Practicals

**Name:** \_\_\_\_\_

**Class:** \_\_\_\_\_





## Contents Page

**Page 2 - 3**

**Specific Heat Capacity**

**Page 4 - 7**

**Resistance**

**Page 8 - 9**

**I-V Characteristics**

**Page 10 - 11**

**Density**

**Page 12 - 13**

**Force and Extension**

**Page 14 - 17**

**Acceleration**

**Page 18 - 22**

**Waves**

**Page 23 - 24**

**Radiation and Absorption**

**Page 25 - 36**

**Answers**

## Learning Objectives -

- Heat up blocks of different metals using an electric heater
- Measure the mass and temperature of the block
- Calculate the work done by the heater
- Plot a graph of temperature change against work done and use the gradient to calculate specific heat capacity of the metal.

Links the decrease of the metal energy store (work done) to the increase in temperature and subsequent thermal energy stored.

## Equipment & Apparatus



## Method:

- 1) Measure the mass of the **copper block** in kg.
- 2) Wrap the **insulation** around the block.
- 3) Place the **immersion heater** into the **larger hole** of the block.
- 4) Connect **ammeter**, **power pack** and heater in **series**.
- 5) Connect the **voltmeter** across the heater.
- 6) Use the **pipette** to put a small amount of **water** in the other hole.
- 7) Put the **thermometer** in the same hole.
- 8) Set the **power** back to **12V**. Switch it on.
- 9) Record the **ammeter** and **voltmeter** readings.
- 10) Take the **starting temperature** reading and start the **stopwatch**.



This will turn on the heater

These shouldn't change

### Safety:

- Do not touch the block or heater when hot - if burnt, run area under cold water for at least five minutes.
- Keep the block on the heatproof mat and allow time for equipment to cool before deconstructing.
- Avoid water spills near power supply - clean up spills.
- Wear eye protection around hot water

Independent variable

- Time

Dependent variable

- Change in temperature

Control variables:

- Block materials
- Current
- Voltage / PD

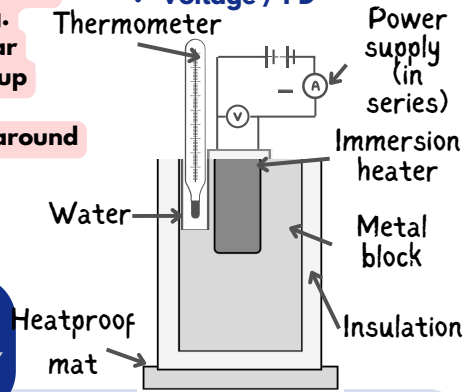

- 11) Record the temperature every **minute** for **10 minutes**.

- 12) Calculate the **power** of the heater in **watts**.

Power (watts) = potential difference (V) x current (I)

- 13) Calculate **energy transferred** (work done, J) by the heater.

Work done (joules, J) = Time (seconds, S) x Power (watts, W)

- 14) Plot a **graph of temperature** (°C) against **work done** (J).

- 15) Draw a **line of best fit**.

The beginning of the graph may be curved

- 16) Calculate the **gradient** of the straight part of the graph.

Gradient =  $\frac{\text{change in temperature rise (}^\circ\text{C)}}{\text{work done (J)}}$

change in y / change in x

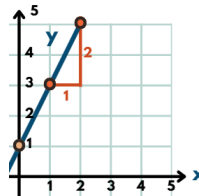

- 17) Calculate the **heat capacity** of the copper block.

Heat capacity = 1 / gradient

The amount of heat energy (J) needed to increase the temperature by 1°C

- 18) Calculate the **specific heat capacity** of the copper block.

The amount of heat energy (J) needed to increase the temperature of 1kg copper by 1°C

Specific heat capacity =  $\frac{\text{Energy transferred (J)}}{\text{mass (kg) x temperature change (}^\circ\text{C)}}$

- 19) Repeat steps 1-18 with aluminium and iron blocks.

Type of metal block	Specific heat capacity (J/Kg/°C)
Copper	385
Aluminium	913
Iron	500

## REQUIRED PRACTICAL 1 SPECIFIC HEAT CAPACITY

### Conclusion

From AQA: "William thinks that denser materials have higher specific heat capacities. Using the density values of the metals below and the values of specific heat capacity that you have calculated, do you agree with him?"

Type of metal block	Density (g/cm <sup>3</sup> )
Copper	8.96
Aluminium	2.70
Iron	7.87

Example: No - copper has the highest density of 8.96g/cm<sup>3</sup> but the lowest specific heat capacity of 385J/Kg/°C. Also, aluminium has the lowest density of 2.70g/cm<sup>3</sup> but the lowest specific heat capacity of 913 J/Kg/°C. So, this hypothesis would be rejected as results suggest the less dense materials have a higher specific heat capacities.

### Evaluation

#### Random errors

- Some **heat will dissipate** into the surroundings
  - Insulation minimises loss,
  - Actual specific heat capacity is likely higher
- **Errors in measurements** from ammeter, voltmeter and stopwatch
  - Use a joulemeter to calculate energy directly
- **Human error** of temperature reading

#### Systematic errors

- **Zero error** - could occur if the ammeter and voltmeter are not initially set to zero.



## Learning Objectives -

- Set up a circuit which can measure the potential difference and current across a wire at different lengths along the wire.
- Calculate the resistance of different lengths of the wire and state the relationship between resistance and length.

## Method:

1) Set up a circuit according to this diagram:

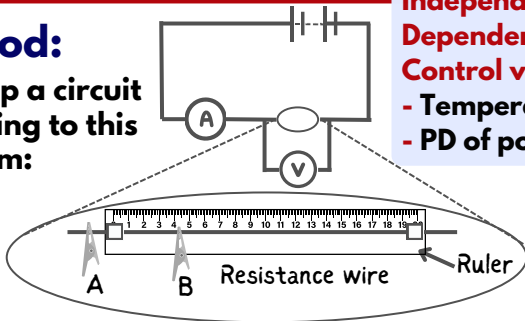

2) Connect a lead from the **negative side** of the **ammeter** to the **crocodile clip (A)** at the **zero end** of the ruler.

Connect a **lead** from the other **crocodile clip (B)** to the **negative side** of the **battery**.

Use this **lead as a switch** to disconnect the battery between readings.

3) Decide the **interval distance** (e.g. 10cm) you will investigate and connect the first distance to be tested **between crocodile clips A and B**.

4) Measure the readings on the **voltmeter** and **ammeter** at this distance.

Record in a table.

5) **Move crocodile clip B** and record the readings for the different lengths of wire e.g. 20cm, 30cm etc.

6) **Calculate** the **resistance for each length** of wire using the equation:

$$\text{resistance in } \Omega = \frac{\text{potential difference in V}}{\text{current in A}}$$

7) Plot a graph of **resistance against length of wire** and draw a line of best fit. Describe the relationship between resistance and length.

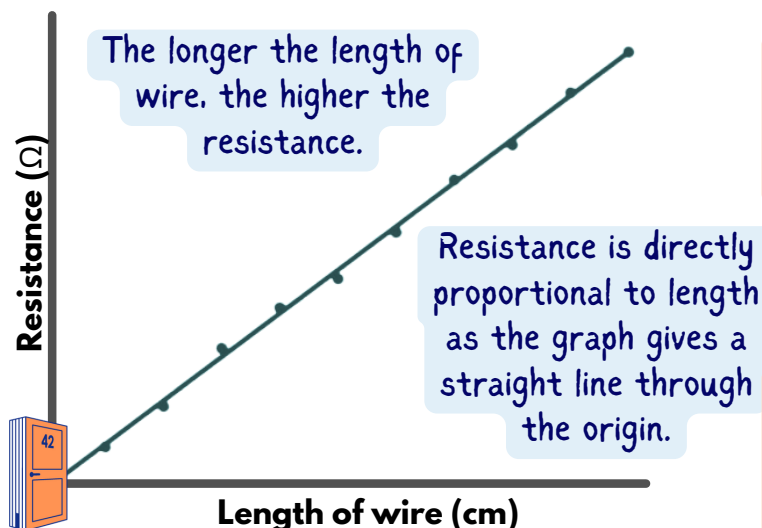

## Equipment & Apparatus



**Voltmeter**

- measure potential difference through the resistors



**Ammeter**

- measure current through the circuit



**Connecting leads**



**Metre ruler**



**Resistance wire**



**12V power supply**

- source of potential difference



**Crocodile clips**

**Independent variable** - length of wire (cm)

**Dependent variable** - resistance ( $\Omega$ )

**Control variables**

- Temperature of the wire

- PD of power supply

Length of wire in cm	Potential difference in volts	Current in amps	Resistance in ohms
e.g. 100	1.20	0.16	7.5
e.g. 90	1.18	0.17	6.8
e.g. 10	0.41	0.63	0.7

$$R = \frac{V}{I}$$

## REQUIRED PRACTICAL 2 RESISTANCE P1 - LENGTH OF WIRE

### Safety Tips:

- Avoid touching the resistance wire when connected or hot; run any burns under cold water for 5-10 minutes.
- Keep liquids away from equipment to prevent electrical damage if spilled.

### Random Errors

- **Limit current flow** to maintain **consistent wire temperature** and resistance.
- **Turn off** current between readings to prevent temperature-related resistance changes.

### Systematic Errors

- Ensure the **first crocodile clip is at 0** on the ruler to avoid zero error in length measurements.
- Check that both the ammeter and voltmeter start from **0**.

The graph may not pass through the origin due to confounding variables that impact both the independent and dependent variables, such as temperature affecting resistance.

- Increased temperature raises resistance as the wire heats up.
- Longer wire lengths lead to higher resistance and more heating.

To minimize confounding variables, it's best to take readings quickly and allow the wire to cool before measuring again, though time constraints in class often make this difficult.

# Exam Style Questions - Resistance P1

1. What is the independent variable in this experiment? (1 mark)

---

2. State the equation used to calculate resistance. (1 mark)

---

---

3. A student tests 50 cm and 100 cm of wire. The current is 0.3 A and the voltages are 0.90 V and 1.80 V respectively. Calculate the resistance for both lengths. (2 marks)

---

---

---

---

4. Explain why the wire should be left to cool between measurements. (2 marks)

---

---

---

---

5. What is the relationship between length of wire and resistance? (2 marks)

---

---

---

---

6. A student plots a graph of resistance against length of wire. The line does not pass through the origin, as expected. Suggest two reasons why. (2 marks)

---

---

---

---

7. Why should the wire used be the same thickness throughout the experiment? (1 mark)

---

---

8. A student finds that resistance is higher at longer lengths. Explain this using particle theory. (3 marks)

---

---

---

---

---

---

9. Suggest one way to reduce random error when measuring current and voltage. (1 mark)

---

---

## Learning Objectives -

- Use circuit diagrams to construct circuits with resistors in series and in parallel
- Measure the potential difference and current in circuits with resistors in series and then in parallel.

## Method:

1) Set up a **circuit** according to this diagram in order to connect the circuit for **two resistors in series**.

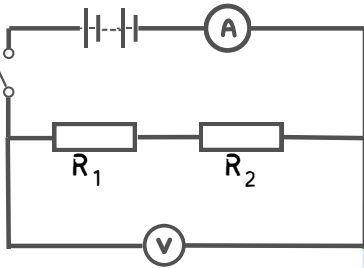

2) Switch on and record the **reading** of the **ammeter** and the **voltmeter**.

3) Calculate the **total resistance** of the series circuit.

4) Set up a **circuit** according to this diagram in order to connect the circuit for **two resistors in parallel**.

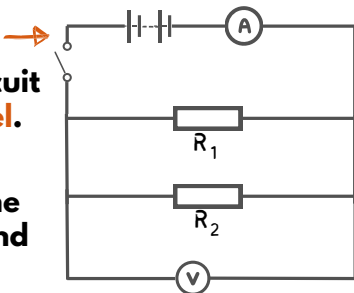

5) Switch on and record the **reading** of the **ammeter** and the **voltmeter**.

6) Calculate the **total resistance** of the parallel circuit.

7) Write a **conclusion** about the effect of adding resistors

- In series
- In parallel

$$R = \frac{V}{I}$$

You can check the value of the resistance of  $R_1$  and  $R_2$  in either circuit by putting each resistor in the circuit on its own and recording the ammeter and voltmeter. The calculation  $R = V / I$  should =  $10\Omega$ .

### ii. In parallel

- Combined resistance of resistors in **parallel is less** than if they were in series because there is an **extra path** for the electrons (therefore current) to flow.
- Therefore, **current is split** and more charge can flow at once, giving a reduced resistance.
- The potential difference across each resistor will be the same as the **power supply** or battery pd.

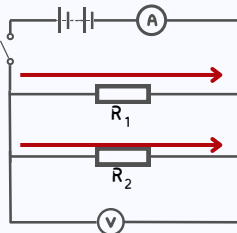

A circuit in parallel is advantageous because it allows components to be individually switched on and off and if one component stops working, they others can continue to work.

$$R = \frac{V}{I}$$

With the current ( $I$ ) increasing but potential difference ( $V$ ) staying the same, the denominator in this equation is being split into larger parts, therefore the calculation results in a smaller number.

## Equipment & Apparatus



**Voltmeter**

- measure potential difference through the resistors



**Ammeter**

- measure current through the circuit



**Connecting leads**



**Switch**



**Crocodile clips**



**2  $10\Omega$  resistor**



**12V power supply (battery)**  
- source of potential difference

**Independent variable** - number of resistors

**Dependent variable** - total resistance ( $\Omega$ )

**Control variables** - Temperature of the resistors and potential difference of the power supply

### i. In series:

- Resistance of combined resistors = sum of two individual resistances**
- Electrons**, therefore the **current, flowthrough one path**
- The **potential difference is split** across the two resistors.

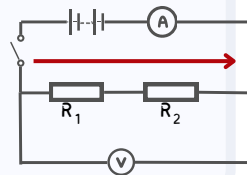

Combined resistance in series ( $R$ ) =  $R_1 + R_2 + R_3$   
Therefore, increasing the number of resistors increases the overall resistance.

## REQUIRED PRACTICAL 2 RESISTANCE - SERIES AND PARALLEL



You can continue this experiment by adding additional resistors in series and parallel to determine the effect.

### Systematic errors

- Check that the ammeter and voltmeter are **calibrated to zero** before taking any recordings.

### Random errors

- Temperature of the wire** can increase when **current is applied** which can affect resistance
  - Minimise **current size** through wire
  - Switch off** circuit between readings of temperature reading

Resistor	Potential difference in volts	Current in amps	Resistance in ohms
Series	4.45V	0.22A	20.2
Parallel	3.94V	0.79A	4.9



# Exam Style Questions - Resistance P2

1. What is the independent variable in this practical? (1 mark)

---

2. Describe the difference in current between a series and parallel circuit. (2 marks)

---

---

---

3. A student sets up two circuits: one in series, one in parallel. The voltage is the same in both. Explain why the total resistance is lower in the parallel circuit. (3 marks)

---

---

---

---

---

4. What is the equation to calculate resistance, and how can it be applied in this practical? (2 marks)

---

---

---

5. A student finds the total resistance in a series circuit is  $9.0 \Omega$  and in a parallel circuit is  $4.9 \Omega$ . What conclusion can they make about adding resistors in parallel vs series? (2 marks)

---

---

---

---

6. Why is it important to use identical resistors in this practical? (1 mark)

---

---

7. In a parallel circuit, the voltage across each resistor is the same. Explain why this means the total current is higher than in a series circuit. (3 marks)

---

---

---

---

---

---

8. A student adds a third identical resistor to a parallel circuit. Predict what happens to the total resistance and explain why. (2 marks)

---

---

---

---

## Learning Objectives -

- Use circuit diagrams to construct appropriate circuits to investigate the I-V characteristics of a variety of circuit elements: 1. a filament lamp, 2. resistor, 3. a diode, at a constant temperature.

### Activity 1 (Filament lamp):

- Set up a circuit according to this diagram:
- Record the readings on the ammeter and voltmeter. Take three readings from the ammeter to calculate an average current.
- Adjust the variable resistor and record new readings on the ammeter and voltmeter.
- Repeat this to obtain readings for 8 voltages.
- Swap the connections on the battery/power supply so that the ammeter is connected to the negative terminal and the variable resistor to the positive terminal.
- Repeat steps 2-4 with the battery reversed. Readings on the voltmeter and ammeter should now be negative.
- Plot a graph of current against potential difference.
- Draw a line of best fit through the origin - this is the characteristics of a filament lamp.

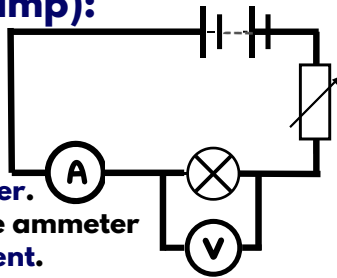

The variable resistor varies the potential difference

### Equipment & Apparatus

- Voltmeter Resolution = 0.1V
- Ammeter Resolution = 0.01A
- Variable resistor Resolution = 0.005Ω
- 12V power supply - source of potential difference (battery)
- Connecting leads
- Filament lamp
- A resistor
- Two resistors
- Diode
- Milliammeter

Activity 1:

Activity 2:

Activity 3:

Voltage (V)	Current I <sub>1</sub> (A)	Current I <sub>2</sub> (A)	Current I <sub>3</sub> (A)	Average Current I (A)
0.5				
...				



#### Safety Tips:

- Avoid touching the resistance wire when connected or hot, especially under high voltages; run any burns under cold water for 5-10 minutes.
- Keep liquids away from equipment to prevent electrical damage if spilled.
- Switch off the circuit between readings to prevent the circuit heating unnecessarily

**Independent variable** - Potential difference, V

**Dependent variable** - Current, I

**Control variables** - Using the same wires and components

## REQUIRED PRACTICAL 3 I-V CHARACTERISTICS

### Activity 2 (Resistor) & Activity 3 (Diode):

The method for taking readings (steps 2 - 8) is the same as activity 1 and should be completed in succession. However, make sure you set up each circuit correctly:

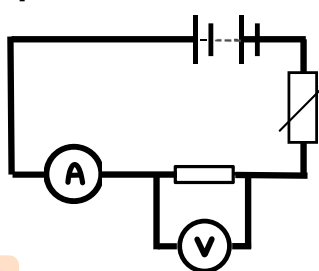

Activity 2:

- Swap the leads on the battery back to their original positions.
- Replace the filament lamp with the resistor.

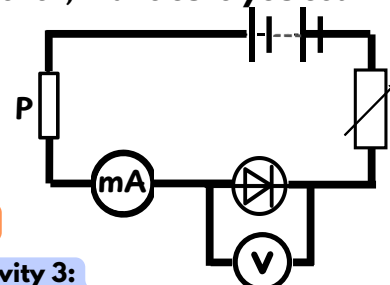

Activity 3:

- Swap the leads on the battery back to their original positions.
- Reduce the battery P.D to <5 V.
- Swap ammeter for the milliammeter
- Replace the resistor with a diode
- Connect the extra resistor, P.

Reduce systematic errors by checking that both the ammeter and voltmeter start from 0.

Variable Resistor

- The variable resistor varies the potential difference.
- If using a battery or power pack with a single setting, the variable resistor allows you to change the p.d. from the fixed voltage.
- If you are using a power pack with a dial, you can simply change the p.d. on the dial

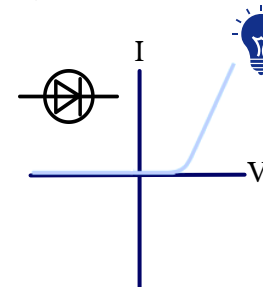

The diode behaves different depending on the polarity of the power supply.

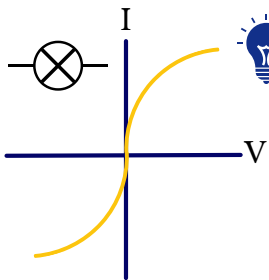

The origin of the graph is in the middle of the paper because there are negative values.

Note: the resistance at any point on the graph is the inverse of the gradient of a line from that point of origin (not the gradient of the graph!)

#### Random Errors

- Limit current flow to maintain consistent wire temperature and resistance.
- Turn off current between readings to prevent temperature-related resistance changes.
- You cannot completely have zero resistance through the ammeter and voltmeter, therefore readings will have some inaccuracies.
- Take three readings for each voltage to reduce anomalous results



# Exam Style Questions - I-V Characteristics

1. What is the independent variable in this experiment? (1 mark)

---

2. What component is used to vary the potential difference across a circuit? (1 mark)

---

---

3. Describe the shape of the I-V graph for a filament lamp. (2 marks)

---

---

---

4. Explain why the filament lamp's resistance increases as the current increases. (3 marks)

---

---

---

---

---

5. What would a graph of current against potential difference look like for a resistor at constant temperature? (1 mark)

---

6. Explain why the resistance of the resistor remains constant during the experiment. (2 marks)

---

---

---

7. The student plots a straight-line graph through the origin.

What does this show about the relationship between current and voltage? (2 marks)

---

---

---

8. Why is there no current when the potential difference is negative in a diode circuit? (2 marks)

---

---

---

---

9. A student says, "The resistance of a filament lamp increases as current increases, but the resistor's resistance stays constant." Use the I-V graphs to explain why the student is correct. (4 marks)

---

---

---

---

---

---

---

## Learning Objectives -

- **Activity 1:** Use a ruler and a balance to determine the density of a regularly shaped object
- **Activity 2:** Use a displacement method to determine the density of an irregularly shaped object
- **Activity 3:** Use measurements of volume and mass to determine the density of a liquid.

## Activity 1:

1) Measure and record the length, width and height of your selected objects.

2) Calculate the volume of each object.

3) Measure the mass of each object using the digital balance.

4) Calculate and record the density of each object using the formula:

$$\rho = \frac{m}{v} \quad \text{density (kg/m}^3\text{)} = \frac{\text{mass (kg)}}{\text{volume (m}^3\text{)}}$$

5) Convert  $\text{g/m}^3$  to  $\text{kg/m}^3$ .

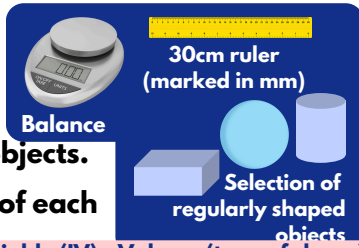

Independent variable (IV) - Volume (type of shape)  
Dependent variable (DV) - Mass of object

$$V = \frac{4}{3}\pi r^3$$

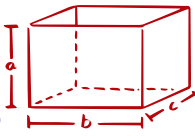

$$V = abc$$

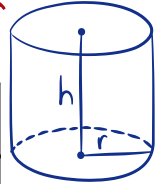

$$V = \pi r^2 h$$

Shaped object	Length (cm)	Height (cm)	Width (cm)	Volume (cm <sup>3</sup> )	Mass (g)	Density (g/cm <sup>3</sup> )
Sphere	1cm = 0.01m					
Cylinder	50cm = 0.5m					
Cuboid						

Record results as you go!

## Activity 2:

1) Measure the mass of one of the irregular shaped objects.

2) Record in a table.

3) Put the displacement can on your desk. Put an empty beaker under the spout and fill the can with water. Water should be dripping from the spout and you should wait until you see this stop.

4) Put a measuring cylinder that you think will give the most accurate reading under the spout instead of the beaker.

5) Very carefully lower the object into the displacement can so that it is completely submerged. Collect all of the water that comes out of the spout in the measuring cylinder.

6) Measure the volume of the collected water. This volume is equal to the volume of the object.

7) Calculate and record the density of the object.

8) Repeat the activity for some other objects. Remember to refill the can with water each time.



Make sure the can is full before adding the object, otherwise the can will continue to fill, before it can spill out!

Shape	Mass (g)	Volume of liquid collected (cm <sup>3</sup> )	Density of irregular shape (g/cm <sup>3</sup> )
Egg			
Doorstop			
Stone			

IV - Irregular shape / mass  
DV - Volume of water displaced

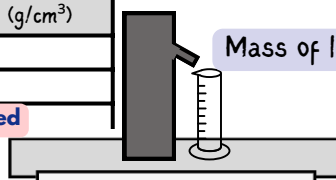

$$\text{Mass of liquid} = \text{Mass of cylinder with water} - \text{mass of empty cylinder}$$

## Evaluation

### Random errors

- **Errors in measurements of length of objects (incorrect volume)**
  - Take multiple readings to calculate an average
- **Dropping** irregular objects from too **high a height** may cause water to splash out, therefore the volume is incorrectly determined.

### Systematic errors

- **Zero error** - could occur if the digital balance is not initially set to zero.
- Different balances may not be identically calibrated
- Rounding errors
- Resolution of measuring cylinders may be different

## Analysis - Explain the differences in density between solids and liquids

E.g. 'The density of a substance depends on how closely its particles are packed. In solids, particles are tightly packed in a fixed structure, making them denser. In liquids, particles are still close but can move around, creating small gaps and lowering density. For example, ice is less dense than liquid water because its particles form an open structure.'

## REQUIRED PRACTICAL 4 DENSITY

Independent variable (IV) - Volume of water added  
Dependent variable (DV) - Mass of cylinder

## Activity 3:

1) Measure the mass of the empty measuring cylinder.

2) Record in a table.

3) Pour about 100cm<sup>3</sup> of the sugar solution into the measuring cylinder. Record the volume accurately

4) Measure and record the mass of the measuring cylinder and liquid. From this calculate and record the mass of just the liquid.

5) Calculate the density of the liquid.

6) Standard units of density are kg/m<sup>3</sup>. Use the data above to calculate the density of the liquid in these units.

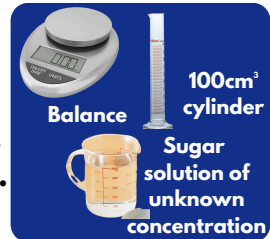

Mass of empty cylinder (g)	Volume of liquid (cm <sup>3</sup> )	Mass of cylinder + liquid (g)	Mass of liquid (g)	Density of liquid (g/cm <sup>3</sup> )



# Exam Style Questions - Density

1. What equipment is needed to measure the volume of a cube or cuboid? (1 mark)

---

2. A metal block has a mass of 540 g and measures 5.0 cm × 3.0 cm × 2.0 cm. Calculate the density in g/cm<sup>3</sup>. (3 marks)

---

---

---

3. Give one reason why it is important to take repeat readings of length when measuring a solid. (1 mark)

---

4. A student places a stone in a displacement can and collects 120 cm<sup>3</sup> of water. The mass of the stone is 300 g. Calculate the density of the stone. (2 marks)

---

---

5. When using a displacement can, explain why it's important to wait until water stops dripping from the spout before taking a reading. (2 marks)

---

---

---

6. A student pours 100 cm<sup>3</sup> of liquid into a measuring cylinder. The mass of the cylinder is 50 g. The total mass of the cylinder and liquid is 130 g. Calculate the density of the liquid in g/cm<sup>3</sup>. (3 marks)

---

---

---

7. Explain why solids usually have a higher density than liquids, using ideas about particle arrangement. (3 marks)

---

---

---

8. A student records the following data:

- Mass of empty measuring cylinder = 60 g
- Mass of cylinder + unknown liquid = 180 g
- Volume of liquid = 150 cm<sup>3</sup>

a) Calculate the mass of the liquid

b) Calculate the density in g/cm<sup>3</sup>

c) Suggest one source of error in this method and how it could be reduced (4 marks)

---

---

---

---

---

---

---

---

## Learning Objectives - Investigate the relationship between force and extension of a spring.

- Hang different masses from a spring and measure the extension of the spring for each mass used.
- Convert mass into weight.
- Use your results to plot a graph of extension against weight.

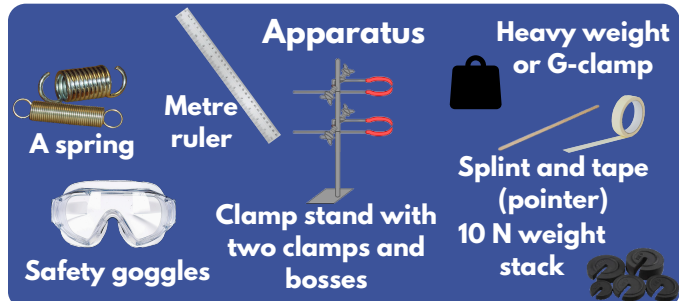

## Method:

1) Set up your apparatus as in the diagram making sure that:

- The ruler is vertical.
- The zero on the scale needs to be at the same height as the top of the spring
- The splint is attached securely to the bottom of the spring.
- Make sure that the splint is horizontal and that it rests against the scale of the ruler.

2) Take a reading on the ruler – this is the length of the unstretched spring.

Record this reading in your results table:

Weight in N	Length of spring in cm	Extension of spring in cm
0.0 (No weight stack added)	220	0
1.0 (weight stack added)	250	30
2.0	280	0
...	...	...

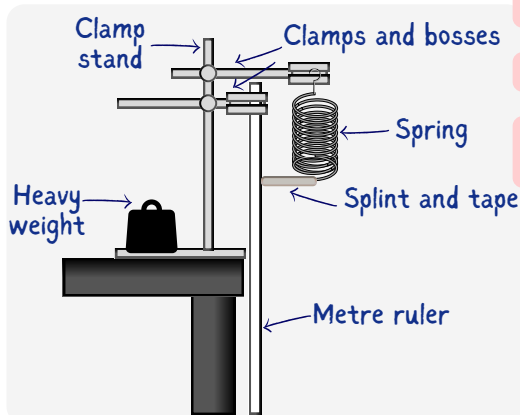

Independent Variable:

- Force,  $F$  (N)

Dependent Variable:

- Extension of the spring,  $e$  (m or cm)

Control Variables:

- Spring used (spring constant,  $k$ )
- Ruler alignment
- Initial length of spring
- Environment (e.g. no air movement, stable temperature)

Safety precautions for the experiment include:

- Wearing goggles protects eyes if the spring snaps springs.
- Placing some soft material below the apparatus catch falling weights
- Using a G clamp to secure the clamp stand to the desk.
- Avoiding excessive pulling on the spring.



A force that stretches or compresses a spring does work, storing elastic potential energy. If the spring is not inelastically deformed, the work done equals the stored energy.

## REQUIRED PRACTICAL 5 FORCE AND EXTENSION

3) Carefully hook the base of a 1.0 newton (1.0N) weight stack onto the bottom of the spring.

4) Take a reading on the ruler.

This is the length of the spring when a force of 1.0 N is applied to it.

5) Add further weights. Measure and record the length of the spring each time.

The force,  $F$  added to the spring is the weight of the mass.  $F = mg$

6) Calculate the extension for each weight and record it on the table.

Don't forget that the mass added will have to be converted to newtons.

Extension = Stretched length - Original length

Hang an object on the spring to measure its extension, then use the graph to find its weight and verify with a newton meter!

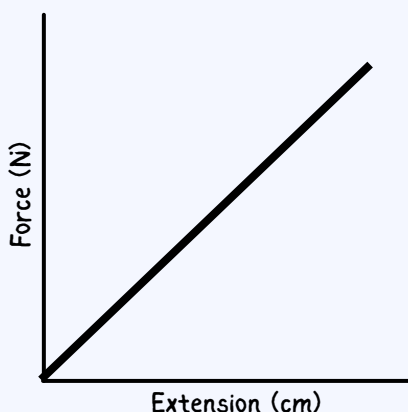

## Analysis of Results

a) State the relationship between force and extension of a wire.

The force applied to a spring or wire is directly proportional to its extension. (– provided the material is not stretched beyond its limit of proportionality.)

b) Calculate the spring constant (force = spring constant  $\times$  extension).

$$k = \frac{F}{e} \quad \text{Example: If a force of 2.0 N causes a spring to extend by 0.04 m: } k = 2.0 / 0.04 = 50 \text{ N/m}$$

c) Calculate the work done in stretching your spring using the equation: Elastic potential energy =  $0.5 \times$  spring constant  $\times$  (extension)<sup>2</sup>

Example: Using  $k = 50 \text{ N/m}$  and  $e = 0.04 \text{ m}$ :

$$E = 0.5 \times 50 \times (0.04)^2 = 0.5 \times 50 \times 0.0016 = 0.04 \text{ J}$$

So, the work done (energy stored) is 0.04 joules.

## Evaluation

### Random Errors

- Use a pointer, such as a fiducial marker to increase the accuracy of the experiment.
- Repeat the measurements for each force three times and calculate an average extension.

### Systematic Errors

- Ensure that measurements on the ruler are taken at eye level to prevent parallax error.
- Before starting, check for a zero error on the ruler to ensure it starts at true zero.

A digital displacement sensor or video analysis tool can enhance precision and eliminate human error in measurements compared to using a ruler.

Go further:

Observe the point where the spring doesn't return to its original length to identify the limit of proportionality and determine if inelastic deformation has occurred.



# Exam Style Questions - Force and Extension

1. What is the independent variable in this experiment? (1 mark)

---

2. What is meant by the “extension” of the spring? (1 mark)

---

3. A student hangs a 2.0 N weight and the spring extends from 200 mm to 250 mm. Calculate the extension in cm. (2 marks)

---

4. What does it mean if the graph of force vs extension curves upwards? (2 marks)

---

5. A spring stretches 0.04 m when a force of 2.0 N is applied. Calculate the spring constant. Give units. (2 marks)

---

7. A student plots a graph of force (N) against extension (cm). The points lie on a straight line until the last two values, which begin to curve.

a) What does the straight section of the graph show?

b) What does the curve at the end indicate? (3 marks)

---

8. A student investigates how the extension of a spring changes when different forces are applied. Describe how they should carry out this experiment and explain how they could ensure their results are valid and reliable.

---

---

---

---

---

---

---

---

---

---

---

---

## Learning Objectives -

To determine how the force applied to a trolley affects its acceleration, while keeping the total mass of the system constant.

This links directly to Newton's Second Law of Motion:

$$F = ma$$

This law tells us that the acceleration of an object is directly proportional to the force applied to it, provided the mass remains unchanged.

## Equipment & Apparatus



## Activity 1:

**1. Marking the bench:** Use the ruler to measure 0.2m intervals on the bench and draw straight lines or place tape across the bench at these intervals.

Make sure it is stable and will not shift during the experiment

**2. Setting Up the Pulley System:** Attach the bench pulley to the end of the bench.

**3. Tie a length of string to the toy car or trolley.** Pass the string over the pulley and attach the weight stack to the other end of the string.

**4. Aligning the System:** Make sure the string is taut and runs horizontally and is in line with the toy car or trolley.

Misalignment can cause extra friction or skew the direction of the force, affecting results.

**5. Preparing for Release:** Hold the toy car or trolley at the start point (0cm) and make sure stationary.

**6. Attach the full weight stack (1.0 N) to the end of the string.**

Recording a video of the sequence will provide more reliable data

**7. Release the toy car or trolley at the same time as you start the stopwatch, press the stop watch (lap mode) at each measured interval on the bench and for the final time at 100 cm.**

To keep the mass of the system constant, each time you remove a mass from the hanger, attach it to the car using Blu-tac

**8. Record the results in the table.**

**9. Repeating with Lower Forces:** Repeat steps 5-8 for decreasing weights on the stack for example, 0.8 N, 0.6 N, 0.4 N, 0.2 N. Make sure you place the masses that you remove from the weight stack onto the top of the car each time you decrease the weight.

For each force level, repeat the entire timing process at least 3 times to reduce the effect of random errors.

**10. Calculate average velocity and acceleration between intervals using the formulas:**

- Velocity ( $v$ ) = Distance  $\div$  Time
- Acceleration ( $a$ ) = (Final velocity - Initial velocity)  $\div$  Time interval

### Independent variable

- Force (N), changed by adjusting the mass hanging from the pulley

### Dependent variable

- Acceleration of the trolley

### Control variables:

- Mass of the system (trolley + weights)
- Surface of the bench
- Starting position
- String length and alignment
- Method of timing

### Safety Considerations:

- Secure weights to prevent falls and injuries.
- Stand beside the pulley system, avoiding direct alignment with falling masses.
- Use a soft buffer or sandbag to safely stop the car and prevent damage or injury.

## REQUIRED PRACTICAL 6 FORCE AND ACCELERATION

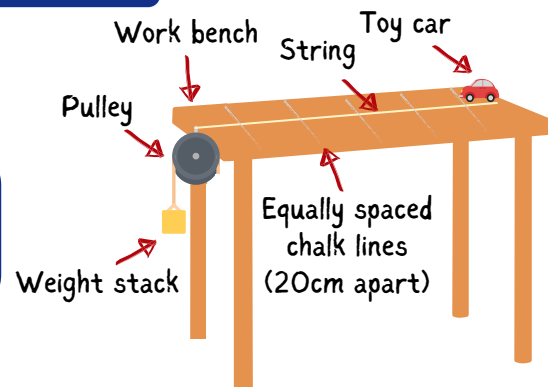
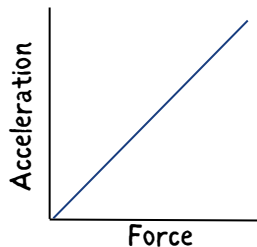

### Expected Results

You should observe that:

- When the force increases, the acceleration of the trolley increases.
- A graph of Force (N) on the x-axis and Acceleration ( $m/s^2$ ) on the y-axis should show a straight line through the origin - a linear relationship.

This is because: Acceleration  $\propto$  Force (when mass is constant), in line with Newton's Second Law,  $F = m \cdot a$

Distance (cm)	Time (s) for 1.0 N	Time (s) for 0.8 N	Time (s) for 0.6 N	Time (s) for 0.4 N	Time (s) for 0.2 N
20					
40					
60					
80					
100					



## Learning Objectives -

Measuring the effect of mass on acceleration with a constant force

This links directly to Newton's Second Law of Motion:

$$m = F/a$$

This law tells us that the acceleration of an object is directly proportional to the force applied to it, provided the mass remains unchanged.

## Equipment & Apparatus



## Activity 2:

1. Setup the bench, pulley, weight stack and car as in steps 1-5 of activity 1.

2. Use your results from activity 1 to select a weight for the weight stack that will just accelerate the car along the bench.

3. Starting with Minimum Mass: Place the trolley at the starting line with its base mass (e.g. 200 g).

4. Hold the car at the start point.

5. Attach your chosen weight stack to the end of the string. Attach the hanging weight and make sure the string is straight and taut.

6. Release the car at the same time as you start the stopwatch, press the stopwatch (lap mode) at each measured interval on the bench and for the final time at 100 cm.

7. Record the results in the table outline below.

8. Increasing the Mass: Repeat the test multiple times, each time increasing the trolley mass by 200 g (e.g. 400 g, 600 g, 800 g, 1000 g). Use Blu-tac to securely attach extra masses.

	Change in mass of the toy car			
Distance (cm)				
20				
40				
60				
80				
100				

9. Calculate average velocity and acceleration at each interval:

- Velocity ( $v$ ) = Distance  $\div$  Time
- Acceleration ( $a$ ) = (Final velocity - Initial velocity)  $\div$  Time interval



In Activity 1, we increased the force ( $F$ ) with weights. This time, we are increasing mass of car ( $m$ )

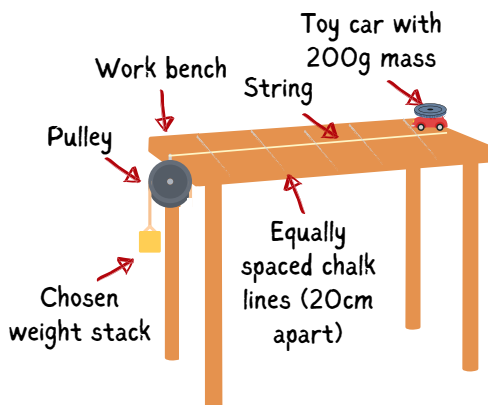

## REQUIRED PRACTICAL 6 FORCE AND ACCELERATION

### Expected Results

You should observe that:

- As mass increases, the acceleration decreases.
- A graph of Mass (kg) on the x-axis vs Acceleration ( $m/s^2$ ) on the y-axis will produce a curve, showing that the relationship is inversely proportional.

This is consistent with the rearranged version of Newton's Second Law:

$$a = F \div m$$

If  $F$  stays the same and  $m$  increases,  $a$  must decrease

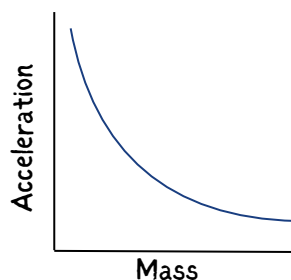

### Independent variable

- Mass of the trolley (changed by adding weights)

### Dependent variable

- Acceleration of the trolley

### Control variables:

- Pulling force (hanging weight stays the same throughout)
- Surface and friction
- Distance travelled
- Surface of the bench
- Starting position
- String length and alignment
- Trolley and pulley system
- Method of Timing

## Evaluation and Reducing Errors (Activities 1 and 2)

### Systematic Errors:

- Forgetting to transfer removed weights to the car changes the systems mass, invalidating results. (Activity 1)

### Random Errors:

- Human reaction time with the stopwatch introduces errors.
- Pulling force may not remain perfectly constant if the string snags or if the pulley sticks.

### Human Errors:

- Not securing masses properly - they may shift or fall during movement.
- Inconsistent release technique may affect timing.

### Improvements:

- Use light gates and a data logger for more accurate timing.
- Repeat the experiment and use mean values to minimize anomalies.
- Ensure the string is straight and horizontal before each release.



# Exam Style Questions - Force and Acceleration

1. What is the independent variable in this experiment? (1 mark)

---

2. How is the force kept constant during this part of the investigation? (1 mark)

---

---

3. A student measures the time for the trolley to travel 1.0 m for five different masses. They notice that the trolley travels more slowly as the mass increases. Explain this result using Newton's Second Law. (3 marks)

---

---

---

---

4. Describe how to ensure this investigation is a fair test. (2 marks)

---

---

5. A student plots a graph of mass against acceleration. What would the shape of the graph be and why? (2 marks)

---

---

---

6. Explain why increasing the mass of the trolley reduces its acceleration. (2 marks)

---

---

7. A student wants to investigate how the mass of a trolley affects its acceleration when pulled by a constant force. Describe the steps they should take to collect valid results and explain what conclusion they could draw from their graph. (6 marks)

---

---

---

---

---

---

---

---

---

---

---

---

## Learning Objectives -

To investigate the relationship between frequency, wavelength, and wave speed in water waves, using a ripple tank to produce and observe the waves.

Waves equation:

$$v = f \lambda$$

Where:  
 $v$  = wave speed (m/s)  
 $f$  = frequency (Hz)  
 $\lambda$  = wavelength (m)

## Equipment & Apparatus

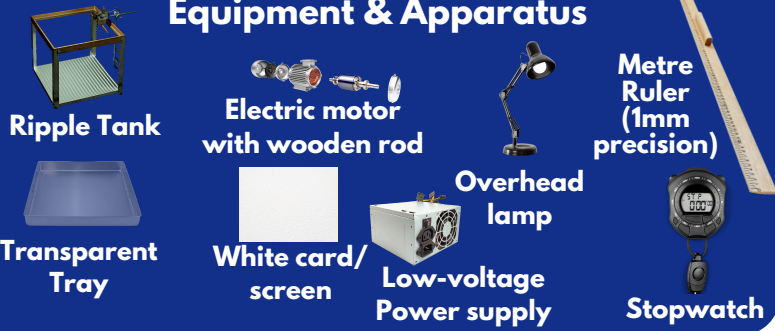

## Activity:

1) **Setting Up the Ripple Tank** - Assemble the ripple tank and position a large white card or screen underneath it.

This makes the wave patterns easier to observe by projecting shadows of the wave crests.

2) **Adding Water** - Pour water into the tank to a depth of approximately 5 mm.

Keep water depth consistent throughout the experiment to maintain uniform wave properties.

3) **Positioning the Wooden Rod** - Adjust the wooden rod on the motor so it just touches the surface of the water. When activated, it will produce regular waves across the water's surface.

### Systematic Errors

Moving wavefronts are difficult to measure.

To improve accuracy of wavelength measurement, use a stroboscope set to the same frequency as the waves - this makes waves appear stationary.

4) **Turning on the Motor and Lamp** - Switch on the overhead lamp and the motor. The lamp should shine directly onto the tank so that shadows of the ripples are clearly seen on the white screen or card.

5) **Producing Low-Frequency Waves** - Adjust the motor via the signal generator to produce low-frequency waves that are easy to observe and count.

6) **Measuring the Wavelength ( $\lambda$ )** - Place the metre ruler at right angles to the wavefronts (across the ripples) on the screen. Measure the across as many waves as you can and divide that length by the number of waves to give you the wavelength.

7) **Measuring the Frequency ( $f$ )** - Count the number of waves passing a point in the pattern over a given time (say 10 seconds). Then divide by the number of waves by 10 to give you the frequency.

• Calculate wave speed:  
 wave speed ( $v$ ) = frequency ( $f$ ) x wavelength ( $\lambda$ )

8) Record results in the table.

Repeat steps 6–8 multiple times and calculate average values to reduce random errors.

## REQUIRED PRACTICAL 7 WATER WAVES IN A RIPPLE TANK

### Random Errors

- Wavelength: Use multiple wave crests to increase measurement accuracy.
- Frequency: Count waves over longer periods then divide by time to calculate frequency more accurately.
- Minimise disturbances (air movement, table vibrations).

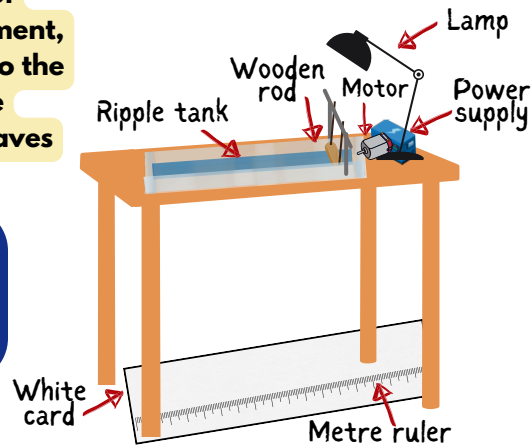

**Independent variable**

- Frequency of the waves (controlled by the motor/signal generator)

**Dependent variable**

- Wavelength of the water waves

**Control variables:**

- Depth of water
- Temperature of water
- Equipment and environment (lamp height, ruler placement)

### Expected Results

You should observe that:

- As frequency increases, the wavelength should decrease (for a constant wave speed).
- A graph of Frequency (Hz) vs Wavelength (m) should show an inverse relationship.
- A graph of Frequency (Hz) vs Wave Speed (m/s) (if varied) may show direct proportionality if all measurements are accurate.

### Safety Considerations:

- Keep electrical equipment away from water; ensure all components are elevated or sealed.
- Stand up throughout the experiment to react quickly to water spills.
- Do not consume food or drink near the apparatus.
- Avoid using strobe lighting if anyone present has photosensitive epilepsy.

Waves in a liquid		
Frequency (Hz)	Wavelength (m)	Speed (m/s)
2	0.025	0.050



# Exam Style Questions - Water Waves in a Ripple Tank

1. What is the purpose of placing a white screen or card under the ripple tank? (1 mark)

---

---

2. Give the wave equation and state what each symbol represent? (2 marks)

---

---

3. A student measures 10 wavelengths across a total distance of 25 cm. Calculate the wavelength. (2 marks)

---

---

3. The student counts 20 waves passing a point in 10 seconds. Calculate the frequency. (2 marks)

---

---

---

4. Describe how the ripple tank should be setup to ensure a fair test and explain why each of the control variables must be kept constant. (4 marks)

---

---

---

---

---

---

---

---

---

---

5. What safety precaution should be followed when using electrical equipment near the ripple tank? (1 mark)

---

---

6. Explain why it is often difficult to measure the wavelength accurately in the ripple tank and suggest two ways the experiment can be improved to reduce this problem. (4 marks)

---

---

---

---

---

---

---

---

---

---

## Learning Objectives -

To observe stationary waves in a solid (string or elastic cord), measure their wavelength and frequency, and use these values to calculate wave speed using the wave equation.

Waves equation:

$$v = f \lambda$$

Where:  
 $v$  = wave speed (m/s)  
 $f$  = frequency (Hz)  
 $\lambda$  = wavelength (m)

This practical helps us understand how waves behave in solids and how the frequency and tension in a string affect the wave pattern.

## Activity:

1) **Setting Up the Apparatus** - Attach one end of the string to the vibration generator. Pass the other end over a pulley, then attach a mass hanger with weights to create tension in the string.

2) **Switching On and Tuning** - Switch on the vibration generator. The string should begin to vibrate. Slowly increase or decrease the frequency using the signal generator until a standing wave pattern forms.

3) **Adjusting for Clarity** - If the wave is not clearly visible, adjust either:

- The length of the string using the bridge
- The tension (by changing the mass on the hanger) until a stable wave pattern forms.

4) **Measuring Wavelength ( $\lambda$ )** - Each complete "loop" of the stationary wave represents half a wavelength ( $\frac{1}{2}\lambda$ ).

Measure the total length across as many half wavelengths as possible using a metre ruler (e.g. 5 loops = 2.5 wavelengths).

- Calculate the full wavelength:  
 $\lambda = (\text{Total length} \div \text{Number of loops}) \times 2$

5) **Recording the Frequency ( $f$ )** -

Read the frequency directly from the signal generator. This is the same as the frequency of the wave on the string.

6) **Calculate wave speed -**

wave speed ( $v$ ) = frequency ( $f$ ) x wavelength ( $\lambda$ )

7) **Repeats and Reliability -**

Repeat the entire measurement for different frequencies (by adjusting the signal generator). For each frequency, record the wavelength and calculate wave speed. Take three readings and calculate the average for each.

Waves in a solid

Frequency (Hz)	Wavelength (m)	Speed (m/s)
60	0.60	36.0

If No. loops = 3  
 and Measured length = 0.90m  
 Wavelength =  $(3 \times 0.9) \times 2 = 0.60\text{m}$

## Equipment & Apparatus



Place a wooden bridge between the generator and pulley to fix the string's vibrating length.

### Independent variable

- Frequency of the waves (adjusted by signal generator)

### Dependent variable

- Wavelength (wave pattern)

### Control variables:

- Type and length of string
- Mass and tension (unless deliberately altered)
- Position of the wooden bridge

The clearest standing wave has nodes (points that don't move) and antinodes (points of maximum vibration) that appear stationary.

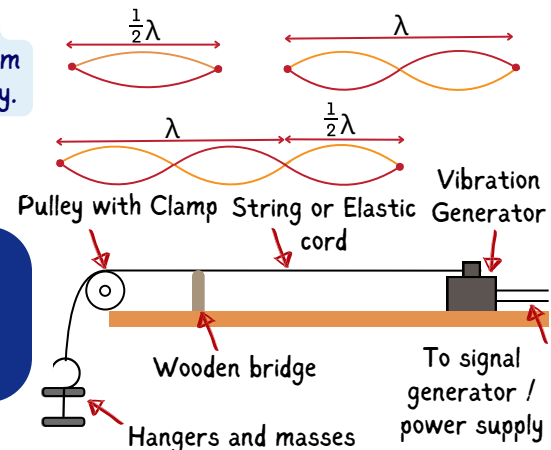

## REQUIRED PRACTICAL 7 MEASURING WAVES IN A SOLID

### Expected Results - You should observe that:

- As frequency increases, the wavelength of the wave generally decreases (assuming constant string tension).
- A graph of frequency vs wavelength will show an inverse relationship.
- A graph of frequency vs wave speed (if tension remains constant) should show wave speed remaining relatively constant for a given string under tension.

### Systematic Errors:

- Stable string tension is crucial; changes in mass or pulley friction affect accuracy.
- Poor wave visibility occurs if frequency is not properly tuned.
- Use the frequency that yields the most visible wave (largest amplitude) and record it accurately.

### Random Errors:

- Measure wavelength across multiple loops for accuracy.
- Repeatability can vary due to slight changes in wave visibility or string tension between trials.

### Safety Considerations:

- Wear safety goggles to protect against snapping strings.
- Use rubber string or cord to minimize injury risk.
- Stand clear of hanging masses to avoid falling objects.
- Use a crash mat or soft surface beneath weights.
- Avoid damp areas for signal generators and wires to prevent electric shock.





## Learning Objectives -

To investigate how the nature of a surface (its colour and texture) affects the amount of infrared radiation it emits or absorbs.

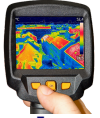

Infrared radiation is a type of electromagnetic wave that transfers heat energy. All objects emit infrared radiation, and the amount depends on their temperature and surface properties.

## Method:

1) Place the Leslie cube on a heat-proof mat to protect the bench surface.

2) Fill the cube almost to the top with boiling water. Use a funnel to avoid spills and burns.

3) Place the lid on top of the cube to reduce heat loss through convection.

4) Wait for one minute to allow the surfaces of the cube to reach the same temperature as the water inside.

5) Use the infrared detector to measure the infrared radiation emitted by each side of the cube:

- Position the detector at the same distance (e.g. 5 cm) from each face.
- Avoid touching or moving the cube.
- Record the infrared radiated from each surface.

6) Repeat the measurement for the following surfaces of the Leslie cube:

- Matt black
- Shiny black
- Matt white
- Shiny silver

7) Record the results in a suitable table.

- Allow the cube to cool before moving.

Surface Type	Infrared Intensity ( $W/m^2$ )
Matt Black	19.5
Shiny Black	14.2
Matt White	5.1
Shiny Silver	3.8

Shiny black

### Systematic Errors:

- Distance from the detector to each cube face must be identical.
  - Solution: Use a measured spacer or block to keep the distance consistent.
- Starting temperatures must be the same.
  - Solution: Use a digital thermometer or temperature probe for precision.
- Infrared detector calibration may drift.
  - Solution: Check baseline readings before starting the test.

### Random Errors:

- Readings may vary due to reflections or background heat.

Solution: Take multiple readings and average them.

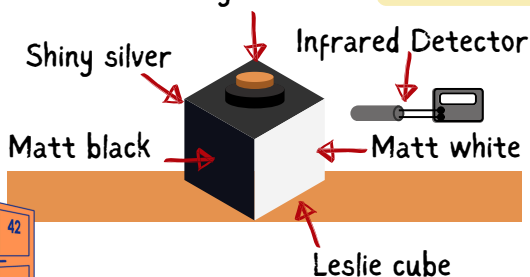

## Equipment & Apparatus



Leslie cube



Kettle



Safety goggles



Stopwatch



Infrared detector



Heatproof mat

Graph paper



### Independent variable

- Surface type/colour (matt black, shiny silver, etc.)

### Dependent variable

- Infrared intensity (from detector)

### Control variables:

- Volume of hot water in cube/flasks
- Starting temperature of water
- Distance between detector and cube surface
- Ambient room conditions (avoid drafts or direct sunlight)
- Time intervals for readings
- Same material and shape of flask (for Method 2)

### Analysis and Interpretation

Plot a bar chart of infrared intensity against surface type.

This helps identify which surface emits the most infrared radiation.

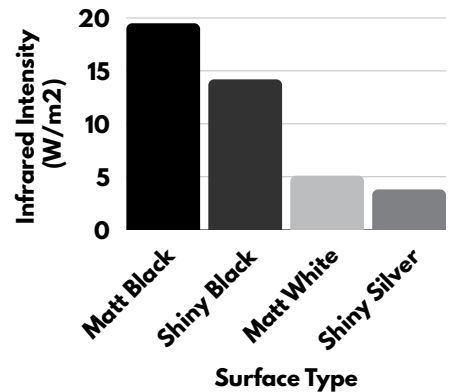

## REQUIRED PRACTICAL 8 RADIATION AND ABSORPTION

### Expected Results - You should observe that:

- Matt black surface: emits and absorbs the most infrared radiation
- Shiny silver surface: emits and absorbs the least
- The order of emission (best to worst):
  - Matt black → Shiny black → Matt white → Shiny silver

This practical shows that surface type influences infrared radiation emission. Darker, duller surfaces are more efficient at emitting and absorbing thermal radiation than lighter, shinier ones.

This helps explain why radiators are often painted black and why survival blankets are silver to reflect body heat.

### Safety Considerations:

- Boiling water can cause scalds; pour slowly, use a funnel, and avoid moving hot cubes.
- Infrared sensors become hot; do not touch the bulb/lens
- Keep electrical equipment away from water.
- Work standing up with a clear workspace to prevent spills.
- Rinse burns under cold water for at least 5 minutes immediately.



# Exam Style Questions - Radiation & Absorption

1. What is the independent variable in this practical? (1 mark)

---

2. Why is it important to wait before taking measurements after pouring the hot water into the Leslie cube? (1 mark)

---

3. What piece of equipment is used to detect the amount of infrared radiation emitted? (1 mark)

---

4. A student records the following infrared intensities:

Matt black = 19.5 units

Shiny silver = 3.5 units

What conclusion can they draw? (2 marks)

---

---

5. Suggest one control variable in this practical and explain why it should be kept the same. (2 marks)

---

---

6. Why must the detector be pointed at the same angle and distance for each reading? (2 marks)

---

---

7. Explain why a matt black surface is better for both emitting and absorbing infrared radiation than a shiny white surface. Use ideas about radiation, reflection and absorption. (4 marks)

---

---

---

---

---

---

8. Suggest three ways you could improve the accuracy or reliability of your results in this practical. (3 marks)

---

---

---

---



# Exam Style Questions - Specific Heat Capacity

1. What is the independent variable in this experiment? (1 mark)

**Mark One** - The type of metal used

2. State two control variables in this experiment. (2 marks)

**Mark One** - Starting temperature

**Mark Two** - Voltage or current / mass of the block

3. Why is the block wrapped in insulation? (1 mark)

**Mark One** - To reduce heat loss to the surroundings

4. What measurements are needed to calculate power? (2 marks)

**Mark One** - Current

**Mark Two** - Potential difference (voltage)

5. Describe how to calculate the energy transferred by the heater. (2 marks)

**Mark One** - Use the equation: Energy transferred = Power  $\times$  time

**Mark Two** - Power = Voltage  $\times$  current

6. A student records a voltage of 12 V, a current of 2.0 A, and heats for 600 seconds.

Calculate the energy transferred. (2 marks)

**Mark One** - Power =  $12 \times 2 = 24 \text{ W}$

**Mark Two** - Energy =  $24 \times 600 = 14,400 \text{ J}$

7. A graph is plotted with temperature ( $^{\circ}\text{C}$ ) on the y-axis and energy transferred (J) on the x-axis.

What is the gradient of the straight-line section used for? (1 mark)

**Mark One** - To calculate the specific heat capacity

8. Give one source of random error in this experiment and how it can be reduced. (2 marks)

**Mark One** - Heat lost to the surroundings

**Mark Two** - Use better insulation or a lid on the block

9. A student wants to compare the specific heat capacity of copper and aluminium using the same method. Describe the method they would use and explain how they would ensure the comparison is valid. Include how they would use the results to calculate the specific heat capacity. (6 marks)

**Level 3 (5–6 marks)**

- Describes a full valid method including: measuring mass, wrapping in insulation, inserting heater and thermometer, recording voltage and current, and logging temperature over time
- Explains how to calculate energy transferred and plot a graph
- Compares results fairly by controlling variables (same power/time/starting temp etc.)

**Level 2 (3–4 marks)**

- Describes a mostly complete method
- Includes how to calculate energy or how to use a graph
- Some mention of fair testing, may miss detail

**Level 1 (1–2 marks)**

- Describes basic idea (e.g. heat metal and measure temperature)
- Limited or no explanation of calculations or fair testing

**0 marks**

- No relevant content



# Exam Style Questions - Resistance P1

1. What is the independent variable in this experiment? (1 mark)

**Mark One** - Length of wire

2. State the equation used to calculate resistance. (1 mark)

**Mark One** - Resistance = potential difference  $\div$  current ( $R = V \div I$ )

3. A student tests 50 cm and 100 cm of wire. The current is 0.3 A and the voltages are 0.90 V and 1.80 V respectively. Calculate the resistance for both lengths. (2 marks)

**Mark One** -  $0.90 \div 0.3 = 3.0 \Omega$

**Mark Two** -  $1.80 \div 0.3 = 6.0 \Omega$

4. Explain why the wire should be left to cool between measurements. (2 marks)

**Mark One** - Heating increases the temperature of the wire

**Mark Two** - This affects the resistance and makes results less accurate

5. What is the relationship between length of wire and resistance? (2 marks)

**Mark One** - Resistance increases with length

**Mark Two** - The relationship is directly proportional (if the graph is a straight line through the origin)

6. A student plots a graph of resistance against length of wire. The line does not pass through the origin, as expected. Suggest two reasons why. (2 marks)

**Mark One** - The first crocodile clip might not have been placed at 0 cm

**Mark Two** - The wire may have warmed up during testing, increasing resistance

7. Why should the wire used be the same thickness throughout the experiment? (1 mark)

**Mark One** - Because thickness affects resistance

8. A student finds that resistance is higher at longer lengths. Explain this using particle theory. (3 marks)

**Mark One** - Electrons move through the metal and collide with atoms

**Mark Two** - A longer wire has more atoms

**Mark Three** - More collisions increase resistance

9. Suggest one way to reduce random error when measuring current and voltage. (1 mark)

**Mark One** - Take multiple readings and calculate a mean / allow wire to cool between readings



# Exam Style Questions - Resistance P2

1. What is the independent variable in this practical? (1 mark)

**Mark One** - The number or arrangement of resistors (series or parallel)

2. Describe the difference in current between a series and parallel circuit. (2 marks)

**Mark One** - In a series circuit, current is the same throughout

**Mark Two** - In a parallel circuit, current splits between branches

3. A student sets up two circuits: one in series, one in parallel. The voltage is the same in both. Explain why the total resistance is lower in the parallel circuit. (3 marks)

**Mark One** - In parallel, there are multiple paths for current to flow

**Mark Two** - More current can flow overall

**Mark Three** - So the total resistance is reduced

4. What is the equation to calculate resistance, and how can it be applied in this practical? (2 marks)

**Mark One** -  $R = V \div I$

**Mark Two** - Measure voltage and current in each circuit, then calculate total resistance

5. A student finds the total resistance in a series circuit is  $9.0 \Omega$  and in a parallel circuit is  $4.9 \Omega$ . What conclusion can they make about adding resistors in parallel vs series? (2 marks)

**Mark One** - Adding resistors in parallel reduces the total resistance

**Mark Two** - Adding resistors in series increases total resistance

6. Why is it important to use identical resistors in this practical? (1 mark)

**Mark One** - So any changes in resistance are only due to the circuit arrangement, not the resistor values

7. In a parallel circuit, the voltage across each resistor is the same. Explain why this means the total current is higher than in a series circuit. (3 marks)

**Mark One** - Each resistor gets the full voltage

**Mark Two** - Each branch draws current independently

**Mark Three** - Total current is the sum of current in each branch

8. A student adds a third identical resistor to a parallel circuit. Predict what happens to the total resistance and explain why. (2 marks)

**Mark One** - The total resistance decreases

**Mark Two** - Because more paths allow current to flow more easily



# Exam Style Questions - I-V Characteristics

1. What is the independent variable in this experiment? (1 mark)

**Mark One** - Potential difference (voltage)

2. What component is used to vary the potential difference across a circuit? (1 mark)

**Mark One** - Variable resistor

3. Describe the shape of the I-V graph for a filament lamp. (2 marks)

**Mark One** - It curves

**Mark Two** - The current increases more slowly at higher voltages

4. Explain why the filament lamp's resistance increases as the current increases. (3 marks)

**Mark One** - More current flows through the filament

**Mark Two** - The filament gets hotter

**Mark Three** - Resistance increases with temperature

5. What would a graph of current against potential difference look like for a resistor at constant temperature? (1 mark)

**Mark One** - A straight line through the origin

6. Explain why the resistance of the resistor remains constant during the experiment. (2 marks)

**Mark One** - The temperature of the resistor stays constant

**Mark Two** - So resistance doesn't change with increasing current

7. The student plots a straight-line graph through the origin.

What does this show about the relationship between current and voltage? (2 marks)

**Mark One** - They are directly proportional

**Mark Two** - Resistance is constant

8. Why is there no current when the potential difference is negative in a diode circuit? (2 marks)

**Mark One** - Diodes only allow current in one direction

**Mark Two** - A reverse potential difference blocks the flow of current

9. A student says, "The resistance of a filament lamp increases as current increases, but the resistor's resistance stays constant." Use the I-V graphs to explain why the student is correct. (4 marks)

**Mark One** - The I-V graph for the filament lamp is a curve

**Mark Two** - This shows current increases more slowly as voltage increases

**Mark Three** - This means resistance is increasing ( $R = V \div I$ )

**Mark Four** - The resistor has a straight-line graph through the origin, showing constant resistance



# Exam Style Questions - Density

1. What equipment is needed to measure the volume of a cube or cuboid? (1 mark)

**Mark One - Ruler**

2. A metal block has a mass of 540 g and measures 5.0 cm × 3.0 cm × 2.0 cm. Calculate the density in g/cm<sup>3</sup>. (3 marks)

**Mark One - Volume = 5 × 3 × 2 = 30 cm<sup>3</sup>**

**Mark Two - Density = 540 ÷ 30 = 18**

**Mark Three - Final answer = 18 g/cm<sup>3</sup>**

3. Give one reason why it is important to take repeat readings of length when measuring a solid. (1 mark)

**Mark One - To reduce random error / improve accuracy**

4. A student places a stone in a displacement can and collects 120 cm<sup>3</sup> of water. The mass of the stone is 300 g. Calculate the density of the stone. (2 marks)

**Mark One - Density = 300 ÷ 120**

**Mark Two - Final answer = 2.5 g/cm<sup>3</sup>**

5. When using a displacement can, explain why it's important to wait until water stops dripping from the spout before taking a reading. (2 marks)

**Mark One - To ensure all the displaced water has been collected**

**Mark Two - So the volume measured is accurate**

6. A student pours 100 cm<sup>3</sup> of liquid into a measuring cylinder. The mass of the cylinder is 50 g. The total mass of the cylinder and liquid is 130 g. Calculate the density of the liquid in g/cm<sup>3</sup>. (3 marks)

**Mark One - Mass of liquid = 130 - 50 = 80 g**

**Mark Two - Volume = 100 cm<sup>3</sup>**

**Mark Three - Density = 80 ÷ 100 = 0.8 g/cm<sup>3</sup>**

7. Explain why solids usually have a higher density than liquids, using ideas about particle arrangement. (3 marks)

**Mark One - In solids, particles are tightly packed in a fixed, regular pattern**

**Mark Two - In liquids, particles are still close but have small gaps between them**

**Mark Three - This means more mass is packed into the same volume in solids, so the density is higher**

8. A student records the following data:

- Mass of empty measuring cylinder = 60 g
- Mass of cylinder + unknown liquid = 180 g
- Volume of liquid = 150 cm<sup>3</sup>

a) Calculate the mass of the liquid

b) Calculate the density in g/cm<sup>3</sup>

c) Suggest one source of error in this method and how it could be reduced (4 marks)

**Mark One - Mass of liquid = 180 - 60 = 120 g**

**Mark Two - Density = 120 ÷ 150 = 0.8 g/cm<sup>3</sup>**

**Mark Three - Source of error: parallax error when reading scale / liquid sticking to the sides**

**Mark Four - Use a digital balance / ensure consistent measuring technique**



# Exam Style Questions - Force and Extension

1. What is the independent variable in this experiment? (1 mark)

**Mark One** - Force applied to the spring

2. What is meant by the “extension” of the spring? (1 mark)

**Mark One** - The increase in length of the spring from its original length

3. A student hangs a 2.0 N weight and the spring extends from 200 mm to 250 mm. Calculate the extension in cm. (2 marks)

**Mark One** - Extension = 250 – 200 = 50 mm

**Mark Two** - Convert to cm = 5.0 cm

4. What does it mean if the graph of force vs extension curves upwards? (2 marks)

**Mark One** - The spring has passed its limit of proportionality

**Mark Two** - It will no longer return to its original shape

5. A spring stretches 0.04 m when a force of 2.0 N is applied. Calculate the spring constant. Give units. (2 marks)

**Mark One** -  $k = F \div e = 2.0 \div 0.04 = 50$

**Mark Two** - Final answer: 50 N/m

6. A student plots a graph of force (N) against extension (cm). The points lie on a straight line until the last two values, which begin to curve.

a) What does the straight section of the graph show?

b) What does the curve at the end indicate? (3 marks)

**Mark One** – The spring obeys Hooke’s Law in the straight-line section

**Mark Two** – Force is directly proportional to extension in this region

**Mark Three** – The curve shows the spring has passed its limit of proportionality

7. A student investigates how the extension of a spring changes when different forces are applied. Describe how they should carry out this experiment and explain how they could ensure their results are valid and reliable.

**Level 3 (5–6 marks)**

- Describes the method clearly, including setting up apparatus, measuring original and stretched length, and calculating extension
- Explains how to ensure accuracy (e.g. using a pointer, reading at eye level, avoiding parallax)
- Describes reliability improvements such as repeating readings and checking proportionality
- Example:
  - Use a clamp stand with spring and ruler
  - Add weights one at a time, measure extension
  - Use a pointer for accuracy, take repeat readings
  - Plot force vs extension graph to check proportional relationship

**Level 2 (3–4 marks)**

- Gives a mostly complete method
- Some valid points on accuracy or reliability
- May lack clarity or miss one key element

**Level 1 (1–2 marks)**

- Describes a basic method or mentions taking measurements
- Limited mention of accuracy or checks

**0 marks**

- No relevant content



# Exam Style Questions - Force and Acceleration

1. What is the independent variable in this experiment? (1 mark)

**Mark One** – The total mass of the system (car + weights)

**Mark Two** – To isolate the effect of force on acceleration

2. Describe how you would use the setup to determine the acceleration of the trolley. (3 marks)

**Mark One** – Use a stopwatch to time the trolley as it passes distance markers (e.g. every 20 cm)

**Mark Two** – Calculate velocity at each interval

**Mark Three** – Use  $\text{acceleration} = (\text{final velocity} - \text{initial velocity}) \div \text{time}$

3. A student times the trolley over two 20 cm intervals. The first time is 1.20 s and the second time is 0.80 s. Calculate the change in velocity and the acceleration. (3 marks)

**Mark One** –  $v_1 = 0.20 \div 1.20 = 0.167 \text{ m/s}$ ;  $v_2 = 0.20 \div 0.80 = 0.25 \text{ m/s}$

**Mark Two** – Change in velocity =  $0.25 - 0.167 = 0.083 \text{ m/s}$

**Mark Three** – Acceleration =  $0.083 \div 0.80 = \text{approx. } 0.104 \text{ m/s}^2$

4. What relationship should the graph of force against acceleration show? (1 mark)

**Mark One** – A directly proportional relationship (straight line through the origin)

5. Suggest one way to reduce random errors in the timing of the trolley. (1 mark)

**Mark One** - Use a light gate or motion sensor instead of a manual stopwatch

6. A trolley is pulled with different weights while keeping the total mass constant. What type of graph should be plotted with the results and what does the shape show? (2 marks)

**Mark One** - Graph of force vs acceleration

**Mark Two** - The shape is a straight line through the origin (directly proportional)

7. A student investigates how the force applied to a trolley affects its acceleration.

Describe how the student should carry out the experiment and explain how they would use their data to reach a valid conclusion. (6 marks)

**Level 3 (5–6 marks):**

- Describes full method, including use of pulley, consistent total mass, measuring acceleration, and plotting graph.
- Includes how to control variables and assess relationship.

**Level 2 (3–4 marks):**

- Gives method and mentions a few valid variables/steps.
- Some mention of calculating or using results.

**Level 1 (1–2 marks):**

- Limited or partial method.
- May mention force or acceleration vaguely.



# Exam Style Questions - Force and Acceleration

1. What is the independent variable in this experiment? (1 mark)

**Mark One** – The mass of the trolley system

2. How is the force kept constant during this part of the investigation? (1 mark)

**Mark One** – By using the same weight stack to pull the trolley each time

3. A student measures the time for the trolley to travel 1.0 m for five different masses. They notice that the trolley travels more slowly as the mass increases. Explain this result using Newton's Second Law. (3 marks)

**Mark One** – Newton's Second Law is  $F = ma$

**Mark Two** – If force is constant and mass increases, acceleration must decrease

**Mark Three** – This explains why heavier masses move more slowly

4. Describe how to ensure this investigation is a fair test. (2 marks)

**Mark One** – Use the same track and pulley setup each time

**Mark Two** – Release the trolley from the same position and use the same force

5. A student plots a graph of mass against acceleration. What would the shape of the graph be and why? (2 marks)

**Mark One** –  $F = ma$ , so if force is constant and mass increases

**Mark Two** – Then acceleration must decrease

6. Explain why increasing the mass of the trolley reduces its acceleration. (2 marks)

**Mark One** – Use the same weight or force each time

**Mark Two** – Do not change the pulling force

7. A student wants to investigate how the mass of a trolley affects its acceleration when pulled by a constant force. Describe the steps they should take to collect valid results and explain what conclusion they could draw from their graph. (6 marks)

**Level 3 (5–6 marks):**

- Describes the method (same pulley, increasing mass, timing),
- explains how to measure acceleration,
- and mentions the expected inverse relationship

**Level 2 (3–4 marks):**

- Reasonable method and idea of acceleration decreasing with mass

**Level 1 (1–2 marks):**

- Basic idea of adding mass and timing trolley;
- lacks clarity on what's measured



# Exam Style Questions - Water Waves in a Ripple Tank

1. What is the purpose of placing a white screen or card under the ripple tank? (1 mark)

**Mark One** - To see the wave shadows more clearly

2. Give the wave equation and state what each symbol represent? (2 marks)

**Mark One** -  $v = f \times \lambda$

**Mark Two** -  $v$  = wave speed,  $f$  = frequency,  $\lambda$  = wavelength

3. A student measures 10 wavelengths across a total distance of 25 cm. Calculate the wavelength. (2 marks)

**Mark One** -  $25 \text{ cm} \div 10 = 2.5 \text{ cm}$

**Mark Two** - Convert to metres = 0.025 m

3. The student counts 20 waves passing a point in 10 seconds. Calculate the frequency. (2 marks)

**Mark One** -  $v = 3.0 \times 0.02$

**Mark Two** - Final answer = 0.06 m/s

4. Describe how the ripple tank should be setup to ensure a fair test and explain why each of the control variables must be kept constant. (4 marks)

**Mark One** - The water depth must be kept the same to maintain consistent wave properties

**Mark Two** - The lamp height should stay constant so shadows remain sharp and clear

**Mark Three** - The same section of the tank should be used for measurement to avoid distortion at the edges

**Mark Four** - Consistent ruler placement and camera/light angle prevent systematic errors

5. What safety precaution should be followed when using electrical equipment near the ripple tank? (1 mark)

**Mark One** - Keep all electrical equipment elevated and dry / avoid spills

6. Explain why it is often difficult to measure the wavelength accurately in the ripple tank and suggest two ways the experiment can be improved to reduce this problem. (4 marks)

**Mark One** - The wave crests are constantly moving, making it hard to line up the ruler accurately

**Mark Two** - Water movement or vibrations may blur the wave pattern

**Mark Three** - Use a stroboscope set to the same frequency to make waves appear stationary

**Mark Four** - Measure across multiple wavelengths and divide to get an average



# Exam Style Questions - Water Waves in a Solid

1. What is meant by a “loop” in a standing wave on a string? (1 mark)

**Mark One** - Half of a wavelength

2. A student observes 5 loops across a string measuring 1.2 m. Calculate the wavelength. (2 marks)

**Mark One** -  $1.2 \div 5 = 0.24$

**Mark Two** - Wavelength =  $0.24 \times 2 = 0.48$  m

3. Suggest one reason the wave pattern may not appear clearly on the string and how to fix it. (2 marks)

**Mark One** - Frequency isn't set correctly / wrong tension

**Mark Two** - Adjust the signal generator or the masses until the wave is stable

4. What is the dependent variable in this experiment? (1 mark)

**Mark One** - The wavelength of the standing wave

5. Why is it better to measure the wavelength across multiple loops instead of just one? (2 marks)

**Mark One** - Reduces random errors

**Mark Two** - Gives a more accurate average wavelength

6. A student increases the frequency and observes more loops form on the string. Explain why this happens. (2 marks)

**Mark One** - Higher frequency = shorter wavelength

**Mark Two** - More half-wavelengths fit on the same length of string

7. Compare how wave speed is measured in the ripple tank and on the vibrating string. Include how wavelength and frequency are measured in each setup and how to improve accuracy. (6 marks)

**Level 3 (5–6 marks):**

- Clearly describes both methods for measuring wavelength and frequency
- Explains how wave speed is calculated in each case using  $v = f \times \lambda$
- Identifies at least one limitation and one improvement for each setup
- (e.g. moving water in ripple tank; stroboscope; difficulty seeing loops on string; tuning frequency for stable pattern)

**Level 2 (3–4 marks):**

- Describes both setups with some correct detail
- Mentions how wave speed is calculated
- Includes one improvement or error source

**Level 1 (1–2 marks):**

- Basic statements about measurement or wave behaviour
- May confuse parts of the method

**0 marks:**

- No relevant content



# Evaluation of Waves Practicals

## 1. State the relationship between the variables measured in activities 1 and 2.

In both activities, we measured the frequency ( $f$ ) and the wavelength ( $\lambda$ ) of waves to calculate the wave speed ( $v$ ) using the equation:  $v = f \times \lambda$ .

In Activity 1 (ripple tank), the independent variable was frequency (changed using the motor), and the dependent variable was wavelength. Wave speed was calculated using the measured frequency and wavelength.

In Activity 2 (vibrating string), the independent variable was also frequency (set using the signal generator), and the dependent variable was the wavelength of the standing wave pattern.

In both cases, the wave speed was derived from the relationship between frequency and wavelength. This confirmed the direct proportionality between wave speed and frequency when wavelength is fixed, and inverse proportionality between frequency and wavelength when speed remains relatively constant.

## 2. Comment on the accuracy of your results in both Activity 1 and 2.

### Activity 1: Ripple Tank

- Wavelength accuracy was affected by wavefront motion, making it hard to precisely align the ruler with the peaks or troughs.
- Frequency accuracy depended on accurate wave counting and consistent timing over 10 seconds. Any miscount or slow reaction with the stopwatch introduced error.
- Accuracy could be improved by using a stroboscope to “freeze” the wave pattern, allowing easier and more reliable wavelength measurements.
- Measuring across multiple wavelengths (e.g., 5–10) reduced random errors.

### Activity 2: Vibrating String

- The frequency readings were accurate, as they were taken directly from the signal generator.
- Wavelength measurement was more reliable than in the ripple tank, especially if measured across multiple loops.
- There was potential for systematic error if the string tension wasn't stable or if the standing wave wasn't fully formed.
- Accuracy improved when waves appeared stationary (clear antinodes), indicating resonance.
- Repeat readings helped ensure reliability, especially when averaging the frequency where wave patterns were most visible.

Overall, results from Activity 2 were typically more accurate and repeatable than those from Activity 1, due to the more controlled conditions and direct digital readout of frequency.

## 3. How suitable was the apparatus that you used in both activities? How might you change the apparatus to provide more accurate results?

### Activity 1: Ripple Tank

- **Suitability:** The apparatus was functional for observing wave behaviour, but it had limitations:
  - Moving wavefronts made measurement difficult.
  - Manual counting of wave crests and use of a stopwatch introduced human error.
- **Improvements:**
  - Use a stroboscope to match wave frequency – this makes the wave appear stationary and simplifies wavelength measurement.
  - Use a high-speed camera or video capture with frame-by-frame analysis to accurately count wave crests and measure timings.
  - Use a calibrated digital frequency generator for more precise frequency control.

### Activity 2: Vibrating String

- **Suitability:** The setup was generally more suitable and produced reliable results.
  - Signal generators provided accurate and adjustable frequencies.
  - The standing wave pattern was clear when the string was correctly tensioned.
- **Improvements:**
  - Use a laser measurement tool or optical sensor to more precisely measure node/antinode positions and wavelengths.
  - Add a tension meter to precisely monitor the string tension, ensuring constant force across trials.
  - Ensure consistent string material and length and reduce friction at the pulley for more controlled conditions.

In both activities, replacing human observation and timing with digital sensors and improving environmental control (e.g., eliminating vibrations, maintaining water depth) would significantly enhance the accuracy and reliability of the results.



# Exam Style Questions - Radiation & Absorption

1. What is the independent variable in this practical? (1 mark)

**One mark** - The type/colour of the surface

2. Why is it important to wait before taking measurements after pouring the hot water into the Leslie cube? (1 mark)

**One mark** - To allow all surfaces of the cube to reach the same temperature

3. What piece of equipment is used to detect the amount of infrared radiation emitted? (1 mark)

**One mark** - Infrared detector

4. A student records the following infrared intensities:

Matt black = 19.5 units

Shiny silver = 3.5 units

What conclusion can they draw? (2 marks)

**Mark one** - To make the readings consistent

**Mark two** - So that the amount of radiation detected only depends on the surface type

5. Suggest one control variable in this practical and explain why it should be kept the same. (2 marks)

**Mark one** - To make the readings consistent

**Mark two** - So that the amount of radiation detected only depends on the surface type

6. Why must the detector be pointed at the same angle and distance for each reading? (2 marks)

**Mark one** - To make the readings consistent

**Mark two** - So that the amount of radiation detected only depends on the surface type

7. Explain why a matt black surface is better for both emitting and absorbing infrared radiation than a shiny white surface. Use ideas about radiation, reflection and absorption. (4 marks)

**Mark One** - Matt black is a good emitter of infrared radiation

**Mark Two** - It is also a good absorber because it does not reflect much radiation

**Mark Three** - Shiny white reflects most radiation

**Mark Four** - So it emits and absorbs much less than black

8. Suggest three ways you could improve the accuracy or reliability of your results in this practical.

**One mark for each of the following, and any other applicable suggestion:**

- Take multiple readings and calculate an average
- Use a fixed distance and angle for all infrared measurements
- Ensure the surfaces of the cube reach the same temperature before recording data